



www.iter-india.org

ITER-India, Institute for Plasma Research

Block A, Sangath SKYZ, Bhat- Motera Road, Koteswar, Ahmedabad 380005 Gujarat,India. Ph.No.

: +91-79-23269656/9575 FAX : +91-79-23269591 / 9501

Email : purchase@iter-india.org

ENQUIRY - LOCAL

OFFICE COPY ENQUIRY NO : I-IEN19047
Date : 15/11/2019
Due Date : 10/12/2019 by 5:00 PM (IST)

We invite your rate/s for the following item/s. The Instructions to bidders and Terms & Conditions are attached herewith.

Important Note :

1. Enquiry No., Date & Due Date should appear on the envelope otherwise your offer will be rejected.
2. Address quotation only to the Purchase officer.

Sr No.	Material Description	Quantity	Unit
1	Pipe Storage Rack	4	NOS

Note :

- (1) Submit your quotation AT THE ABOVE ADDRESS.
- (2) Any clarification on this enquiry may be sought from the Purchase Officer, ITER-India
- (3) Quote with complete technical details.
- (4) Quotation should invariably be submitted in the attached format (Quotation Format) ONLY else ITER-India may not consider your offer.
- (5) Signed & stamped copy of enquiry, technical specification and drawings as attached to be submitted with the offer & this shall be considered as an acceptance on complete enquiry document by the bidder.
- (6) Safety requirement - As the work is to be executed in a restricted area, the Supplier / contractor shall strictly observe all safety, security and labour regulations prevailing in the campus. The Contractor shall be responsible for the proper behavior of the staff employed by him and also for any breach of security regulations, thefts, sabotage etc. The Contractor shall withdraw any person so desired by ITER-India, if in the opinion of the representative of ITER-India it is not desirable to permit that particular person to work inside the campus.
- (7) Accident Liability - The Supplier will take all possible precautions to avoid damage to the Purchaser's property during its onsite activities. Supplier shall also take insurance covering third party liability for the personnel and equipments deployed at Purchaser's site against all risks, such as injuries, loss of life etc. Supplier will be fully responsible for payment of compensation. In the event of loss or damage to Purchaser's property and/or injury or loss of life to Purchaser's personnel during the course of onsite activities due to Supplier's default, Supplier will be fully responsible and liable for such damages/losses and payment of appropriate compensation. Contractor will relieve the Purchaser from all the liabilities under this clause.
- (8) Income tax (TDS), as applicable, at a prevailing rate as per section 194C of Income Tax Act and prevailing rate as per GST act on the Total Contract Value will be deducted from the invoice. Bidder shall submit the PAN along with the bid. Certificate of TDS will be issued by the Purchaser.
- (9) The bidder under the category of MSME Enterprise shall attach a MSME Certificate (Udhyog Aadhar) along with the offer.
- (10) Payment shall be made within 30 days from the date of final acceptance of ordered items of purchaser and on receipt of error free invoice and other necessary documents at our end.
- (11) Bidder should visit our site at Cryogenics Lab, Ground Floor, ITER-India Building, Institute for Plasma Research, Bhat, Gandhinagar - 382428 submit site visit confirmation as per attached Annexure-1(a). Bidder needs to contact Mr. Vinit

fe

Shukla (Mobile No. 9067432884) before coming for site visit.

Encl:- as above

Rakhi Dharamdasani
OFFICER-I (PURCHASE & STORES)
ITER-India (IPR)

TERMS AND CONDITIONS

1. The quotation and any order resulting from this enquiry shall be governed by our Conditions of Order and supplier quoting against this enquiry shall be deemed to have read and understood the same in to
2. Where counter terms and conditions have been offered by the Tenderer, the same shall not be deemed to have been accepted by ITER-India unless our specific written acceptance thereof is obtained.
3. Quotation: Your quotation superscripting our enquiry No., date, due date and brief description of item should be submitted to the Purchase Officer, ITER-India in sealed envelope on or before the due date. Late/ Delayed/incomplete quotations will not be considered. Envelopes received without Enquiry number, date, due date and brief description of item may be rejected. The quoted prices should be firm for a period of 90 days from due date for placing order. ITER-India is not bound to accept lowest rate/s. Bidder shall submit the price bid/offer on Bidder's letter head with official seal and sign on each page.
4. The bid documents shall be prepared in English language only
5. All pages of the bid documents shall be numbered. Each page of the bid document shall be stamped and initialized.
6. In the event of any date indicated above is a declared Holiday, the next working day with the same time limit shall become operative for the respective purpose mentioned herein
7. In case of deviation in payment terms including demand of advance other than specified in payment schedule and accepted by ITER-India, prevailing Prime Lending Rate (PLR) of SBI will be loaded for price comparison purpose
8. ITER-India and their authorized representatives may visit the Contractor/Sub-contractors if required as part of technical evaluation process
9. ITER-India reserves the right to place order on one or more parties.
10. Specifications: Material should be offered strictly conforming to our specifications/drawings, if any. Deviation, if any, should be clearly indicated by the supplier in their quotation. The Tenderer should also indicate the Make/Type number of the materials offered and catalogues, technical literature and samples, wherever necessary should accompany the quotation. Clarification/s on specifications/drawings should be obtained from Purchase Officer before submitting quotation.
11. Terms of Prices: Quotation should be submitted on door delivery basis, duly packed & insured without extra charge wherever possible.. In the case of Indian suppliers, the material is to be delivered at our stores free of charge duly packed & insured.
12. Unit rate/s should be valid throughout the validity of Purchase Order for addition/deletion purposes. Break-up of price should be furnished. The quoted price should not be subject to price escalation for whatsoever reasons. The quoted price shall be firm, fixed and non-revisable during the validity/ extended validity of Purchase Order.
13. Prices are required to be quoted according to the units indicated in the tender form/Enquiry. When Quotations are given in terms of units other than those specified in the tender form, relationship between the two sets of units must be furnished.
14. Tender should be free from Correction and Erasures. Corrections, if any, must be attested. All amounts shall be indicated both in words as well as in figures. Where there is difference between amounts quoted in words and figures, amount quoted in words shall prevail. Unsigned quotations will summarily be rejected.
15. ITER-India shall be under no obligation to accept the lowest or any tender and reserves the right of acceptance of the whole or any part of the tender or portion of the quantity offered and the tenderers shall supply the same at the rates quoted. ITER-India also reserves the right to split the order at its sole discretion.
16. Octroi is not applicable at present.
17. Earnest Money Deposit (EMD): Tenderer should furnish EMD if asked for by the purchaser.
18. Delivery Date/Period: Delivery period is essence of the Order. Supplier must indicate the firm delivery date by which the materials will be dispatched / delivered by them from the date of our order.
19. Delivery period shall be clearly indicated against each item separately.
20. Inspection: Materials on its arrival at ITER-India will be inspected by our Engineer/Stores In-Charge, and his decision in the matter will be final. However, where the items are required to be inspected at the Suppliers Premises, Supplier has to give advance notice to the Purchaser regarding readiness of the material to enable Purchase/Stores section to depute his representative for inspection.
21. Payment: Payment will be arranged for accepted materials only within 30 days from the date of acceptance of materials at ITER-India and receipt of error free bills in our accounts section, complete in all respects.
22. No correspondence will be entertained within 30 days from the date of receipt of material and bills, whichever is later.
23. Warranty: The Stores/Items offered should be guaranteed for a minimum period of twelve months from the date of acceptance, against defective materials, design, workmanship, operation or manufacture. For defects noticed and communicated during the Guarantee period, replacement/rectification should be arranged free of cost within a reasonable period of such notification. In case where our specifications call for a guarantee period more than 12 months specifically, then such a period shall apply.
24. The Contractor/Supplier shall at all times indemnify the purchaser against all claims which may be made in respect of the stores for infringement of any right protected by Patent, Registration of design or Trade Mark and shall take all risk of accidents or damage, which may cause failure of supply from whatever cause arising and the entire responsibility for sufficiency of all means used by him for the fulfillment of the Order.
25. Successful tenderer will have to furnish in the form a Bank Guarantee or in Indemnity Bond form as called for by the Purchaser towards adequate security for the materials/property provided/issued by the Purchaser as Free Issue Material for the due execution of the Order. Insurance for the Free Issue Material shall be arranged by the Supplier/Contractor at his risk and cost.
26. Non-compliance to tender specifications and/or tender scope and/or tender terms and conditions are liable for rejection. Decision of ITER-India in respect of non-compliance shall be final and binding on the bidders.
27. Canvassing in any form with regard to this tender will lead to rejection of the bid.
28. The Project Director, ITER-India reserves the right to accept or reject any quotations fully or partly or to cancel the enquiry without assigning any reasons.
29. This enquiry is not a commitment and the Purchaser reserves the right to reject or cancel any or all offers.
30. Jurisdiction: The Order shall be governed by the Laws of India for the time being in force. The Courts of Ahmedabad/Gandhinagar only shall have jurisdiction to deal with and decide any legal or dispute arising out of this Order.
31. Unsuccessful bidders will not be intimated about the results of the enquiry/tender.
32. Purchase will not be responsible for payment of any interest to the Supplier, in case of delay in releasing payment.
33. The price evaluation shall be carried out on Landed price.

FORMAT FOR SUBMISSION OF QUOTATION

Enquiry No. : I-IEN19047
Name Of Party : OFFICE COPY
Quotation No. & Date :
Due on : 10/12/2019 by 5:00 PM(IST)

Sr No.	Material Description	Qty	Unit	Rate	Total
1	Pipe Storage Rack	4	NOS		
				Grand Total	

COMMERCIAL TERMS & CONDITIONS *

Sr.No	Description	Bidder's Compliance
1	Free Door Delivery	
2	Payment:ITER-India payment terms will apply (Please Refer Sr. No. 10 of Note)	Comply Yes/No (In case of No Please provide details)
3	Warranty (Refer Sr.No. 23 Of Terms and Condition)	Comply Yes/No (In case of No Please provide details)
4	Validity Period (Refer Sr. No. 3 of Terms and Conditions)	Comply Yes/No (In case of No Please provide details)
5	Completion Period (within 15 days from the date of Purchase Order)	Comply Yes/No (In case of No Please provide details)
6	GST (Not included in quoted price)	
7	GST No. (To Specify)	
8	SAC Code (To Specify)	
9	Udhyog Aadhar No. & Category (Micro/Small/Medium Enterprise)	
10	Discount(if any)	
11	Remarks	

* Fill in the applicable details

Place:

Authorised Signatory:

Date:

Company Seal

Enq. No. I-IEN19047 Annexure – I
Technical Specification for Fabrication of Pipe storage racks

Scope of work:-

1. Fabrication of Pipe storage racks (4 Nos.) as per drawing given in annexure-1.
2. All fabrication activities like cutting, handling, fit-up, welding and painting shall be carried out at site (ITER-India cryogenic laboratory, IPR).
3. Handling of pipes for managing the space before fabrication activities
4. Shifting of pipes in the pipe storage rack after fabrication
5. All welding activities will be performed by Electric Arc Welding.

Free issue material:

The following materials will be provided by ITER-INDIA

1. Material (MS material "C" channels, Size- 50mmX100mm, total length ~50 meter) required for fabrication of pipe storage racks, please note that in case of shortage of material, remaining material will be taken from outside the lab area.
2. 14" Chop saw cutting m/c and 4" hand grinder machines.
3. During fabrication of the structure, ITER-India will provide the overhead crane (please refer note), required power supply for the equipment used for cutting, welding etc. Storage for the equipment shall also be provide inside the lab.

Scope of material from vendor side:-

Vendor has to arrange welding M/C, Man power required for handling and fabrication work, shielding or purging gas, welding consumable, material required for painting and any other material, tools, consumables etc. required to complete scope of work.

General Terms and Condition

1. The job needs to be carried out at ITER-INDIA Cryogenics lab, IPR, safe procedure to be adopted for working all the time.
2. During hot work, precaution has to be taken to prevent any un-wanted incidents.
3. The vendor has to take necessary precaution for the safe lifting and positioning of the material.
4. The vendor shall arrange all applicable equipment & tools except free issue materials for execution and completion of the job
5. All the safety precautions shall be arranged by the vendor. Also vendor shall obey IPR safety rules/norms during site work.
6. The vendor shall ensure that all their staff and workers shall wear safety Helmet and Safety shoes (will be managed by vendor itself) and other required PPEs as per work conditions. Vendor shall also ensure use of safety belt, protective goggles, and gloves etc. by the personnel as per job requirements and as specified by IPR safety officer.
7. Ensuring non-damage of pre-installed structures and pre-installed lab facilities during the work.

Note: Before quoting for the said job, vendor shall need to visit the site and make himself acquainted with the scope of the job and quote accordingly. After the site visit, vendor shall provide a confirmation about the clear understanding of scope of work.

Final Acceptance

On completion of work, the ITER-India representative would inspect all fabrication activities like cutting, fit-up, welding and painting mentioned in the scope of work. After his clearance, final acceptance shall be given for the work completion.

Housekeeping

Vendor shall ensure that a high degree of housekeeping is maintained and shall ensure inter alia the followings wherever applicable.

1. All Scraps and debris has to be removed/disposed of from the working areas to identified location(s).
2. Utmost care shall be taken to ensure over all cleanliness and proper upkeep the working areas.

Schedule

Work shall be completed within a period of **15 working days** from the date of release of Purchase order.

Annexure-I (a): Site visit confirmation
Annexure-I (a)
(To be printed on bidder's letter head and submitted with the quotation)

Date:

Enquiry / Tender No.	
Date	
Item Description	
Due Date for Bid submission	

This is to confirm that

Mr.

of Messrs.

has / have visited the site at ITER-India Lab, Institute for Plasma Research on

				2	0		
--	--	--	--	---	---	--	--

to understand the scope of supply, work, technical specifications and get acquainted with the tender requirements related to above mentioned enquiry / tender.

(Bidder's signature)

Date:

Coordinator, ITER-India, IPR

ANNEXURE - I (b)

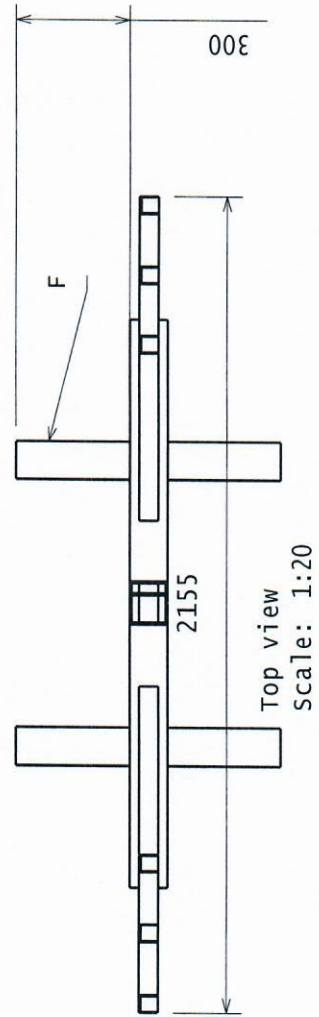
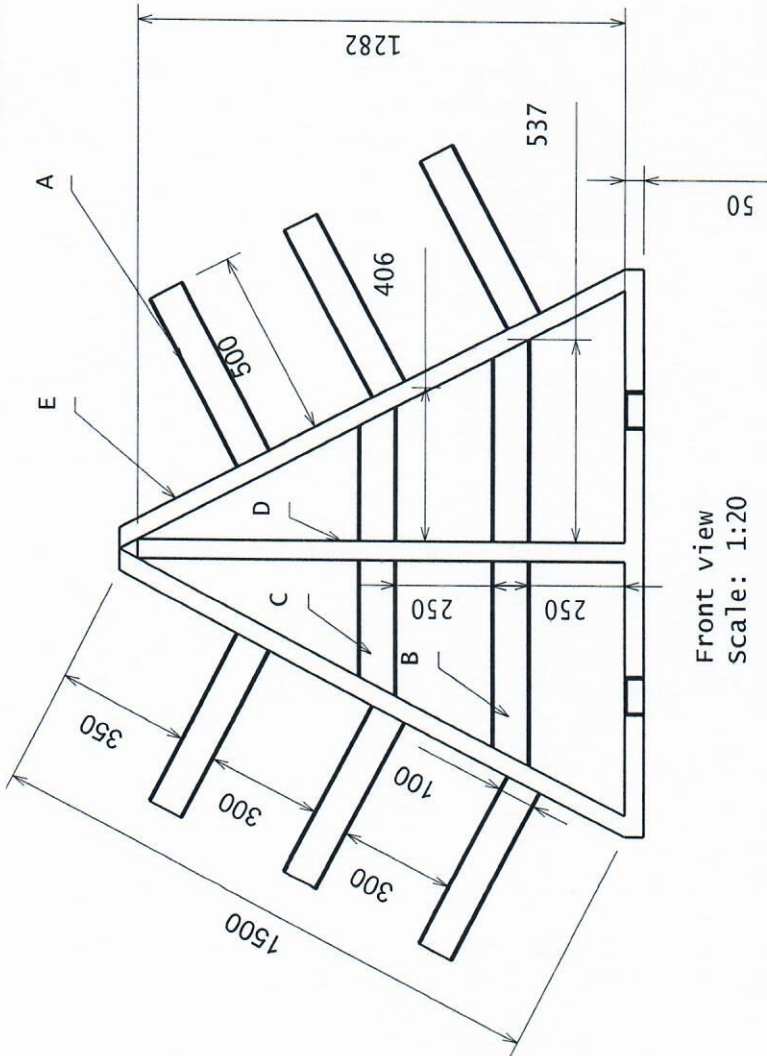

Bill of Material					
Sr. No.	Part no.	Dimensions (mm)	Quantity	Material	
1	A	100 x 50 x 500	6	M.S.	
2	B	100 x 50 x 537	2	M.S.	
3	C	100 x 50 x 406	2	M.S.	
4	D	100 x 50 x 1282	1	M.S.	
5	E	100 x 50 x 1500	3	M.S.	
6	F	100 x 50 x 300	4	M.S.	
				Total length in 1 stand = 11868mm	