



www.iter-india.org

## ITER-India, Institute for Plasma Research

Block A, Sangath SKYZ, Bhat- Motera Road, Koteswar, Ahmedabad 380005 Gujarat, India. Ph.No.

: +91-79-23269656/9575 FAX : +91-79-23269591 / 9501

Email : toc@iter-india.org

### ENQUIRY – LOCAL (Reminder-1)

OFFICE COPY                      ENQUIRY NO                      : I-IEN20020  
Date                                      : 15/07/2020  
Due Date                                : 28/07/2020 by 5:00 PM (IST)

We invite your rate/s for the following item/s. The Instructions to bidders and Terms & Conditions are attached herewith.

#### Important Note :

1. Enquiry No., Date & Due Date should appear on the envelope otherwise your offer will be rejected.
2. Address quotation only to the Purchase officer.
3. ITER-India, IPR is entitled to avail concessional rate of GST @ 5% (2.5% CGST and 2.5% SGST) as per Central Goods and Services Tax (CGST) Notification No. 45/2017-Central Tax (Rate) dated 14th November, 2017, State Goods and Services Tax (SGST) Notification No. 45/2017 – State Tax (Rate) dated 15th November, 2017 and IGST @ 5% as per Notification No. 47/2017-Integrated Tax (Rate) dated 14th November, 2017. Therefore, please consider GST in your quotation accordingly.

Sr No.	Material Description	Quantity	Unit
1	Air insulated indoor Dis-connector Switch Unit with Earth Switch (Refer attachment for detailed specifications)	1	SET

#### Note :

- (1) Submit your quotation duly signed and stamped in a sealed envelope AT THE ABOVE ADDRESS. You can also submit password protection quotation duly stamped and signed in soft copy through email sent to toc@iter-india.org only along with Password so as to open the document. It is mandatory to mention the mobile no. of your contact person in your quotation.
- (2) Any clarification on this enquiry may be sought from the Purchase Officer, ITER-India (purchase@iter-india.org)
- (3) Quote with complete technical details.
- (4) Quotation should invariably be submitted in the attached format (Quotation Format) ONLY else ITER-India may not consider your offer.
- (5) Payment shall be made within 30 days from the date of final acceptance of ordered items of purchaser's site and on receipt of error free invoice and other necessary documents at our end.
- (6) Bidders are requested to filled the vendor's Compliance column in the Technical specification as per attached Annexure-A and return back along with the enquiry documents (duly signed and stamped). Refer Annexure-A for Technical Specifications. (Pages-4). Proposed GA drawings of item to be attached along with the offer.
- (7) Bidder under the category of MSE (Micro & Small Enterprise) for the quoted item shall attach MSE certificate. Under MSE category, only manufacturers for goods and Service Providers for Services are eligible under the policy. Traders are excluded from the purview of this Policy.

Encl:- as above

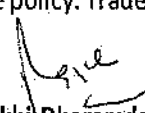
  
Rakhi Dharamdasani  
OFFICER-I (PURCHASE & STORES)  
ITER-India (IPR)

## TERMS AND CONDITIONS

1. The quotation and any order resulting from this enquiry shall be governed by our Conditions of Order and supplier quoting against this enquiry shall be deemed to have read and understood the same in to
2. Where counter terms and conditions have been offered by the Tenderer, the same shall not be deemed to have been accepted by ITER-India unless our specific written acceptance thereof is obtained.
3. Quotation: Your quotation superscripting our enquiry No., date, due date and brief description of item should be submitted to the Purchase Officer, ITER-India in sealed envelope on or before the due date. Late/Delayed/incomplete quotations will not be considered. Envelopes received without Enquiry number, date, due date and brief description of item may be rejected. The quoted prices should be firm for a period of 90 days from due date for placing order. ITER-India is not bound to accept lowest rate/s. Bidders shall submit the price bid/offer on Bidder's letter head with official seal and sign on each page.
4. The bid documents shall be prepared in English language only
5. All pages of the bid documents shall be numbered. Each page of the bid document shall be stamped and initialized.
6. In the event of any date indicated above is a declared Holiday, the next working day with the same time limit shall become operative for the respective purpose mentioned herein
7. In case of deviation in payment terms including demand of advance other than specified in payment schedule and accepted by ITER-India, prevailing Prime Lending Rate (PLR) of SBI will be loaded for price comparison purpose
8. ITER-India and their authorized representatives may visit the Contractor/Sub-contractors if required as part of technical evaluation process
9. ITER-India reserves the right to place order on one or more parties.
10. Specifications: Material should be offered strictly conforming to our specifications/drawings, if any. Deviation, if any, should be clearly indicated by the supplier in their quotation. The Tenderer should also indicate the Make/Type number of the materials offered and catalogues, technical literature and samples, wherever necessary should accompany the quotation. Clarification/s on specifications/drawings should be obtained from Purchase Officer before submitting quotation.
11. Terms of Prices: Quotation should be submitted on door delivery basis, duly packed & insured without extra charge wherever possible. In the case of Indian suppliers, the material is to be delivered at our stores free of charge duly packed & insured.
12. Unit rate/s should be valid throughout the validity of Purchase Order for addition/deletion purposes. Break-up of price should be furnished. The quoted price should not be subject to price escalation for whatsoever reasons. The quoted price shall be firm, fixed and non-revisable during the validity/extended validity of Purchase Order.
13. Prices are required to be quoted according to the units indicated in the tender form/Enquiry. When Quotations are given in terms of units other than those specified in the tender form, relationship between the two sets of units must be furnished.
14. Tenders should be free from Correction and Erasures. Corrections, if any, must be attested. All amounts shall be indicated both in words as well as in figures. Where there is difference between amounts quoted in words and figures, amount quoted in words shall prevail. Unsigned quotations will summarily be rejected.
15. ITER-India shall be under no obligation to accept the lowest or any tender and reserves the right of acceptance of the whole or any part of the tender or portion of the quantity offered and the tenderers shall supply the same at the rates quoted. ITER-India also reserves the right to split the order at its sole discretion.
16. Octroi is not applicable at present.
17. Delivery Date/Period: Delivery period is essence of the Order. Supplier must indicate the firm delivery date by which the materials will be dispatched / delivered by them from the date of our order.
18. Delivery period shall be clearly indicated against each item separately.
19. Inspection: Materials on its arrival at ITER-India will be inspected by our Engineer/Stores In-Charge, and his decision in the matter will be final. However, where the items are required to be inspected at the Suppliers Premises, Supplier has to give advance notice to the Purchaser regarding readiness of the material to enable Purchase/Stores section to depute his representative for inspection.
20. Payment: Payment will be arranged for accepted materials only within 30 days from the date of acceptance of materials at ITER-India and receipt of error free bills in our accounts section, complete in all respects.
21. No correspondence will be entertained within 30 days from the date of receipt of material and bills, whichever is later.
22. Warranty: The Stores/Items offered should be guaranteed for a minimum period of twelve months from the date of acceptance, against defective materials, design, workmanship, operation or manufacture. For defects noticed and communicated during the Guarantee period, replacement/rectification should be arranged free of cost within a reasonable period of such notification. In case where our specifications call for a guarantee period more than 12 months specifically, then such a period shall apply.
23. The Contractor/Supplier shall at all times indemnify the purchaser against all claims which may be made in respect of the stores for infringement of any right protected by Patent, Registration of design or Trade Mark and shall take all risk of accidents or damage, which may cause failure of supply from whatever cause arising and the entire responsibility for sufficiency of all means used by him for the fulfillment of the Order.
24. Successful tenderer will have to furnish in the form a Bank Guarantee or in Indemnity Bond form as called for by the Purchaser towards adequate security for the materials/property provided/issued by the Purchaser as Free Issue Material for the due execution of the Order. Insurance for the Free Issue Material shall be arranged by the Supplier/Contractor at his risk and cost.
25. Non-compliance to tender specifications and/or tender scope and/or tender terms and conditions are liable for rejection. Decision of ITER-India in respect of non-compliance shall be final and binding on the bidders.
26. Canvassing in any form with regard to this tender will lead to rejection of the bid.
27. The Project Director, ITER-India reserves the right to accept or reject any quotations fully or partly or to cancel the enquiry without assigning any reasons.
28. This enquiry is not a commitment and the Purchaser reserves the right to reject or cancel any or all offers.
29. Jurisdiction: The Order shall be governed by the Laws of India for the time being in force. The Courts of Ahmedabad/Gandhinagar only shall have jurisdiction to deal with and decide any legal or dispute arising out of this Order.
30. Unsuccessful bidders will not be intimated about the results of the enquiry/tender.
31. Purchase will not be responsible for payment of any interest to the Supplier, in case of delay in releasing payment.
32. The price evaluation shall be carried out on Landed price.

## FORMAT FOR SUBMISSION OF QUOTATION

Enquiry No. : I-HEN20020  
Name Of Party : OFFICE COPY  
Quotation No. & Date :  
Due on : 28/07/2020 by 5:00 PM (IST)

Sr No.	Material Description	Qty	Unit	Rate	Total
1	Air insulated indoor Dis-connector Switch Unit with Earth Switch (Refer attachment for detailed specifications)	1	SET		
				Grand Total	

### COMMERCIAL TERMS & CONDITIONS \*

Sr.No	Description	Bidder's Compliance
1	Free Door delivery	
2	Packing & Forwarding (To Specify, if any)	
3	Safe Delivery Charges (Please mention if not included in rate mention above)	
4	Delivery Period (Refer Sr. No. 4 of attached Annexure-A)	Comply Yes/No (In case of No Please provide details)
5	Payment:ITER-India payment terms will apply (Refer Sr. No. 5 of Note)	Comply Yes/No (In case of No Please provide details)
6	Warranty (Refer Sr. No. 7 of attached Annexure-A)	Comply Yes/No (In case of No Please provide details)
7	Validity Period (Refer Sr.No. 3 Of Terms and Condition)	Comply Yes/No (In case of No Please provide details)
8	GST (Refer Sr.No. 3 of Important Note)	Comply Yes/No (In case of No Please provide details)
9	GST (Not to be included in quoted rates) (Mention GST% & confirm GST extra)	
10	GST Registration No. (To specify)	
11	HSN Code	
12	Udhyog Aadhar No. & Category (Micro/Small Enterprise)	
13	Discount (If any)	
14	Remarks	

\* Fill in the applicable details

Place:

Authorised Signatory:

Date:

Company Seal



## Technical specification for Air insulated indoor Dis-connector Unit with Earth Switch

### 1. Scope of Supply

S.No	Name of the Item	Quantity
1.	Supply of the Air-insulated indoor dis-connector with earth switch as per the following technical specifications.	1 Sets

### 2. Technical Specifications:

S.No	ITER-India Specifications		Vendor Compliance
1.	Type	Air insulated indoor dis-connector with vertical-break contacts and earth switch on load side	
2.	Compliance Standard	IEC 62271-102 or its Equivalent	
3.	Rated voltage (Ur)	24 kV AC	
4.	Continuous current rating	400 A or nearest standard rating	
5.	Rated frequency	50Hz	
6.	Number of pole	2 pole	
7.	Rated Insulation level	<i>Dielectric withstand voltage 1 min/50Hz</i> 50kV – common value	
		60kV – across isolating distance	
8.	Rated short time withstand current	25kA, 1 sec	
9.	Mounting position	<b>Horizontal or Vertical*</b> (Refer Section 3 for details)	
10.	Mechanical endurance class	Specify (Class M2 or M0 )	
11.	Detail of Insulator & Fire behaviour	Cast epoxy resin	
12.	Type of Operating Mechanism	1. Motorized Operation 2. Manual Operation (Additional provision to be provided with manual crank handle to operate dis-connector switch in event of motor drive is not healthy)	
13.	Fixed contact material	Copper or Casted Copper or Nickel Plated Copper	
14.	Control Box	1. Dis-connector to be provided with a control box to operate the dis-connector (open and close).	

**Annexure-A Technical Specifications**

Enq.No. : I-IEN20020

Date: 25.06.2020

		2. Control box shall be loose having cable length of at least 10meters, to be mounted at separate location 3. Rated supply voltage for auxiliary and control circuit - 230V,50Hz AC Single phase, two-wire system OR - 400V,50Hz AC Three phase, three-wire system 4. Control box assembly shall comply to relevant IEC / National standard	
15.	Auxiliary switch / Micro switch to signal the disconnector position	2 NC + 2 NO (potential free contacts dedicated for user)	
16.	Configuration for disconnectors	Disconnector with earth bar, moving contacts connected to earth bar in open position  <u>Refer Annexure for Suggested Drawing</u>	

**3. Instructions for Manufacturing & Factory Testing:**

- A) If a vertical mounted unit is offered, then, suitable mechanism (such as crank rod, gearbox assembly etc., must be included in the scope of supply).
- B) If a floor mounted unit is offered, then, suitable mechanism (with wheels with arrestors) must be incorporated which allows the user to move unit easily.
- C) Earth Switch (or Earthing knife) shall be interlocked and to be on the load side
- D) A typical suggestive drawing is given in Annexure for reference purpose only.
- E) Prior approval of drawings shall be taken from ITER-India.
- F) All the accessories (motors, gearbox, insulators control wires etc.,) shall be of reputed manufacturers only and of complying relevant standards.
- G) **Factory Testing:** The Unit shall be tested at factory works for Visual Inspection, IR Tests, HV Isolation tests, etc., for the verification of key technical specifications.

**4. Delivery**

The required delivery schedule period is within 2 Months from the date of purchase order. Faster delivery is preferred.

**5. Packing & Shipment**

The material should be appropriately packed with one set of documentation & Prior information of the material dispatch should be given to ITER-India Purchase Officer. The items shall be delivered at following address:

**ECRH-Lab,  
ITER-India Lab Building,  
Institute for Plasma Research,  
Near Indira Bridge, P.O. Bhat Gandhinagar -382 428, India**

	<b>Annexure-A Technical Specifications</b>	Enq.No.: I-IEN20020
		Date: 25.06.2020

**6. Final Acceptance:**

After the receipt of the unit at ITER-India site, ITER-India shall conduct performance tests on the unit. Upon successful completion of the tests (after resolving issues completely, if any) at site, a final acceptance note shall be issued by ITER-India. The date of issuance of final acceptance note shall be considered as the date of final acceptance.

**7. Warranty:**

A minimum of one-year warranty should be provided from the date of final acceptance.

**8. Notes for Bid Submission**

- A) Specification compliance sheet has to be filled by vendor as shown in technical specification sheet.
- B) Proposed GA drawings of Unit may be attached along with the bid.
- C) A reference drawing is presented in annexure for understanding, manufacturer can do improvements along with complying with specifications.

9. Annexure-1

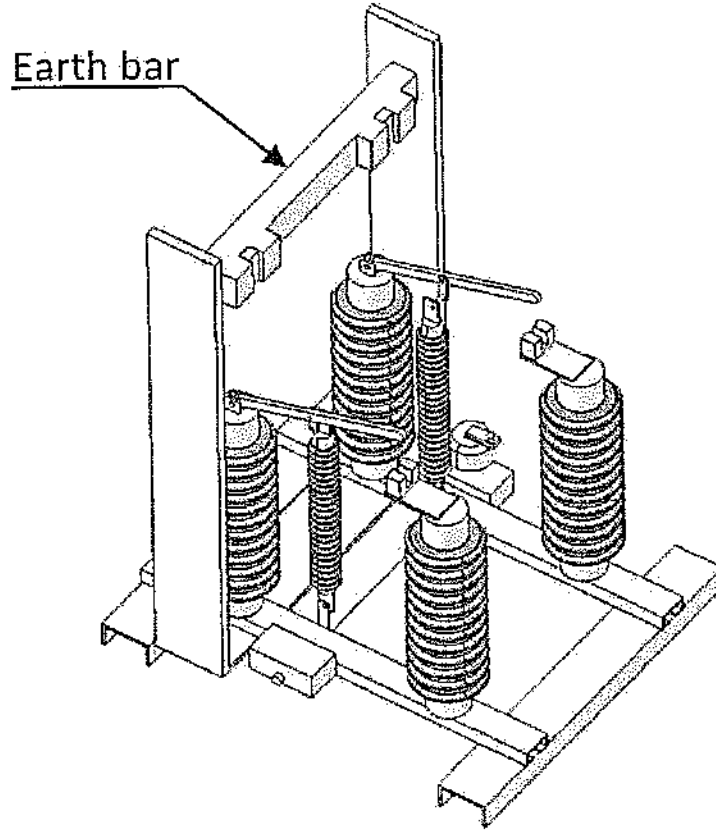

Figure 1 Suggested scheme for Dis-Connector with Earth Switch Configuration

Bidder Signature		
Name of the signatory & Title		Title
Bidder's Official seal		
Place & Date	Place	DD-MM-YYYY