



www.iterindia.in

ITER-India, Institute for Plasma Research

Block A, Sangath SKYZ, Bhat- Motera Road, Koteswar, Ahmedabad 380005 Gujarat, India.

Ph.No. : +91-79-23269656/9575 FAX : +91-79-23269591 / 9501

Email : purchase@iterindia.in

ENQUIRY - LOCAL

OFFICE COPY ENQUIRY NO : I-IEN22029
Date : 17/01/2023
Due Date : 14/02/2023 by 5:00 PM (IST)

We invite your rate/s for the following item/s. The Instructions to bidders and Terms & Conditions are attached herewith.

Important note :

1. Enquiry No., Date & Due Date should appear on the envelope otherwise your offer will be rejected.
2. Address quotation only to the Sr. Officer (Purchase & Stores).

Sr No.	Material Description	Quantity	Unit
1	Maintenance platform with ladder- wall mount type fabrication and installation work	1	AU

Note :

- (1) Submit your quotation AT THE ABOVE ADDRESS.
- (2) Any clarification on this enquiry may be sought from the Purchase Officer, ITER-India. (Email id: purchase@iterindia.in)
- (3) Quote with complete technical details.
- (4) Quotation should invariably be submitted in the attached format (quotation Format) ONLY else ITER-India may not consider your offer
- (5) Detailed specifications & other terms are as per attached Annexure-A. Complete Annexure-A shall be signed & stamped on each page by bidder & to be return back along with the offer. This will be considered as an acceptance of bidder on Annexure-A.
- (6) Any bidder from a country that shares a land border with India(i) , excluding countries as listed on the website of the Ministry of External Affairs(ii) , to which the Government of India has extended lines of credit or in which the Government of India is engaged in development projects (hereinafter called 'Restricted Countries') shall be eligible to bid in this tender only if Bidder is registered (iii) with the Registration Committee constituted by the Department for Promotion of Industry and Internal Trade (DPIIT). Bidders shall enclose the certificate in this regard as per Annexure-II. (i) <https://mea.gov.in/india-and-neighbours.htm> (ii) <http://meadashboard.gov.in/indicators/92> (iii) https://dipp.gov.in/sites/default/files/Revised-Application-Format-for-Registration-of-Bidders-15_Oct_2020.pdf
- (7) Bidder from such Restricted Countries" means: - a) An entity incorporated, established, or registered in such a country; or b) A subsidiary of an entity incorporated, established, or registered in such a country; or c) An entity substantially controlled through entities incorporated, established, or registered in such a country; or d) An entity whose beneficial owner is situated in such a country; or e) An Indian (or other) agent of such an entity; or f) A natural person who is a citizen of such a country; or g) A consortium/ joint venture where any member falls under any of the above.
- (8) In Bids for Turnkey contracts, including Works contracts, the successful bidder shall not be allowed to sub-contract works to any contractor from such Restricted Countries unless such contractor is similarly registered. In such cases, the bidders shall enclose the certificate as per Annexure II.
- (9) If Bidder has proposed to sub-contract Services or incidental Goods directly/ indirectly from the vendors from such countries, such vendor shall be required to be registered with the Competent Authority. However, if Bidder procures raw material, components, and sub-assemblies from such countries"" vendors, such vendors shall not require registration.

- (10) Purchase preference to Micro and Small Enterprises (MSEs): Purchase preference will be given to MSEs as defined in Public Procurement Policy for Micro and Small Enterprises (MSEs) Order, 2012 dated 23.03.2012 issued by Ministry of Micro, Small and Medium Enterprises and its subsequent Orders/Notifications issued by concerned Ministry. If the bidder wants to avail the Purchase preference, the bidder must be the manufacturer of the offered product in case of bid for supply of goods. Traders are excluded from the purview of Public Procurement Policy for Micro and Small Enterprises. In respect of bid for Services, the bidder must be the Service provider of the offered Service. Relevant documentary evidence in this regard shall be uploaded along with the bid in respect of the offered product or service. If L-1 is not an MSE and MSE Seller (s) has/have quoted price within L-1+ 15% (Selected by Buyer) of margin of purchase preference /price band defined in relevant policy, such Seller shall be given opportunity to match L-1 price and contract will be awarded for 100%(selected by Buyer) percentage of total QUANTITY.
- (11) Preference to Make In India products: Preference shall be given to Class 1 local supplier as defined in public procurement (Preference to Make in India), Order 2017 as amended from time to time and its subsequent Orders/Notifications issued by concerned Nodal Ministry for specific Goods/Products. The minimum local content to qualify as a Class 1 local supplier is denoted in the bid document. If the bidder wants to avail the Purchase preference, the bidder must upload a certificate from the OEM regarding the percentage of the local content and the details of locations at which the local value addition is made along with their bid, failing which no purchase preference shall be granted. In case the bid value is more than Rs 10 Crore, the declaration relating to percentage of local content shall be certified by the statutory auditor or cost auditor, if the OEM is a company and by a practicing cost accountant or a chartered accountant for OEMs other than companies as per the Public Procurement (preference to Make-in -India) order 2017 dated 04.06.2020. Only Class-I and Class-II Local suppliers as per MII order dated 4.6.2020 will be eligible to bid. Non - Local suppliers as per MII order dated 04.06.2020 are not eligible to participate. However, eligible micro and small enterprises will be allowed to participate. In case Buyer has selected Purchase preference to Micro and Small Enterprises clause in the bid, the same will get precedence over this clause. (Minimum 50% & 20% local contents require for qualifying as Class I & Class II local supplier respectively)
- (12) Class-I Local Suppliers and Class-II Local Suppliers will submit duly signed self declaration on their letter head as per Annexure-II along with the offer.
- (13) GeM Availability report ID : GEM/GARPTS/11012023/2LYFTHOBCZ0Z dated 11.01.2023.
- (14) Following documents to be submitted by the bidders along with bids.
- I. Annexure-A duly filled, signed & stamped (along with Drawings as per Annexure-I).
 - II. Self-Declaration by Bidder of a country sharing/not sharing land border with India as per Annexure-II.
 - III. Declaration of Class-I & Class-II as per Annexure-III.

Encl:- as above



Rakhi Dharamdasani
Sr. Officer (Purchase & Stores)
ITER-India (IPR)

TERMS AND CONDITIONS

1. The quotation and any order resulting from this enquiry shall be governed by our Conditions of Order and supplier quoting against this enquiry shall be deemed to have read and understood the same in to
2. Where counter terms and conditions have been offered by the Tenderer, the same shall not be deemed to have been accepted by ITER-India unless our specific written acceptance thereof is obtained.
3. Quotation: Your quotation superscripting our enquiry No., date, due date and brief description of item should be submitted to the Purchase Officer, ITER-India in sealed envelope on or before the due date. Late/ delayed/incomplete quotations will not be considered. Envelopes received without Enquiry number, date, due date and brief description of item may be rejected. The quoted prices should be firm for a period of 90 days from due date for placing order. ITER-India is not bound to accept lowest rate/s. Bidder shall submit the price bid/offer on bidder's letter head with official seal and sign on each page.
4. The bid documents shall be prepared in English language only
5. All pages of the bid documents shall be numbered. Each page of the bid document shall be stamped and initialized.
6. In the event of any date indicated above is a declared Holiday, the next working day with the same time limit shall become operative for the respective purpose mentioned herein
7. In case of deviation in payment terms including demand of advance other than specified in payment schedule and accepted by ITER-India, prevailing Prime lending Rate (PLR) of SBI will be loaded for price comparison purpose
8. ITER-India and their authorized representatives may visit the Contractor/Sub-contractors if required as part of technical evaluation process
9. ITER-India reserves the right to place order on one or more parties.
10. Specifications: Material should be offered strictly conforming to our specifications/drawings, if any. Deviation, if any, should be clearly indicated by the supplier in their quotation. The Tenderer should also indicate the make/Type number of the materials offered and catalogues, technical literature and samples, wherever necessary should accompany the quotation. Clarification/s on specifications/drawings should be obtained from Purchase Officer before submitting quotation.
11. Terms of Prices : Quotation should be submitted on door delivery basis, duly packed & insured without extra charge wherever possible. In the case of Indian suppliers, the material is to be delivered at our stores free of charge duly packed & insured.
12. Unit rate/s should be valid throughout the validity of Purchase Order for addition/deletion purposes. Break-up of price should be furnished. The quoted price should not be subject to price escalation for whatsoever reasons. The quoted price shall be firm, fixed and non-revisable during the validity/ extended validity of Purchase Order.
13. Prices are required to be quoted according to the units indicated in the tender form/Enquiry. When Quotations are given in terms of units other than those specified in the tender form, relationship between the two sets of units must be furnished.
14. Tender should be free from Correction and Erasures. Corrections, if any, must be attested. All amounts shall be indicated both in words as well as in figures. Where there is difference between amounts quoted in words and figures, amount quoted in words shall prevail. Unsigned quotations will summarily be rejected.
15. ITER-India shall be under no obligation to accept the lowest or any tender and reserves the right of acceptance of the whole or any part of the tender or portion of the quantity offered and the tenderers shall supply the same at the rates quoted. ITER-India also reserves the right to split the order at its sole discretion.
16. Octroi is not applicable at present.
17. Delivery date/Period: Delivery period is essence of the Order. Supplier must indicate the firm delivery date by which the materials will be dispatched / delivered by them from the date of our order.
18. Delivery period shall be clearly indicated against each item separately.
19. Inspection: Materials on its arrival at ITER-India will be inspected by our Engineer/Stores In-Charge, and his decision in the matter will be final. However, where the items are required to be inspected at the Suppliers Premises, Supplier has to give advance notice to the Purchaser regarding readiness of the material to enable Purchase/Stores section to depute his representative for inspection.
20. Payment: Payment will be arranged for accepted materials only within 30 days from the date of acceptance of materials at ITER-India and receipt of error free bills in our accounts section, complete in all respects.
21. No correspondence will be entertained within 30 days from the date of receipt of material and bills, whichever is later.
22. Guarantee: The Stores/Items offered should be guaranteed for a minimum period of twelve months from the date of acceptance, against defective materials, design, workmanship, operation or manufacture. For defects noticed and communicated during the Guarantee period, replacement/rectification should be arranged free of cost within a reasonable period of such notification. In case where our specifications call for a guarantee period more than 12 months specifically, then such a period shall apply.
23. The Contractor/Supplier shall at all times indemnify the purchaser against all claims which may be made in respect of the stores for infringement of any right protected by Patent, Registration of design or Trade mark and shall take all risk of accidents or damage, which may cause failure of supply from whatever cause arising and the entire responsibility for sufficiency of all means used by him for the fulfillment of the Order.
24. Successful tenderer will have to furnish in the form a bank Guarantee or in Indemnity bond form as called for by the Purchaser towards adequate security for the materials/property provided/issued by the Purchaser as Free Issue material for the due execution of the Order. Insurance for the Free Issue material shall be arranged by the Supplier/Contractor at his risk and cost.
25. Non-compliance to tender specifications and/or tender scope and/or tender terms and conditions are liable for rejection. Decision of ITER-India in respect of non-compliance shall be final and binding on the bidders.
26. Canvassing in any form with regard to this tender will lead to rejection of the bid.
27. The Project director, ITER-India reserves the right to accept or reject any quotations fully or partly or to cancel the enquiry without assigning any reasons.
28. This enquiry is not a commitment and the Purchaser reserves the right to reject or cancel any or all offers.
29. Jurisdiction: The Order shall be governed by the laws of India for the time being in force. The Courts of Ahmedabad/Gandhinagar only shall have jurisdiction to deal with and decide any legal or dispute arising out of this Order.
30. Unsuccessful bidders will not be intimated about the results of the enquiry/tender.
31. Purchase will not be responsible for payment of any interest to the Supplier, in case of delay in releasing payment.
32. The price evaluation shall be carried out on landed price.

FORMAT FOR SUBMISSION OF QUOTATION

Enquiry No. : I-IEN22029
Name of Party : OFFICE COPY
quotation No. & Date :
Due on : 14/02/2023 by 5:00 PM (IST)

Sr no.	Material Description	Qty	Unit	Rate	Total
1	Maintenance platform with ladder- wall mount type fabrication and installation work	1	AU		
				Grand Total	

COMMERCIAL TERMS & CONDITIONS *

Sr.no	Description	Bidder's Compliance
1	Firm Price	Comply Yes/No (In case of No Please provide details)
2	Completion Period (within 1 Months)	Comply Yes/No (In case of No Please provide details)
3	Payment: ITER-India payment terms will apply (Please Refer Sr. No. 20 of Terms & Conditions)	Comply Yes/No (In case of No Please provide details)
4	Bid Validity Period (Refer Sr. No. 3 of Terms and Conditions)	Comply Yes/No (In case of No Please provide details)
5	GST Inclusive/ Exclusive (To Specify as % of GST applicable)	
6	GST No. (To Specify)	
7	Warranty (Refer Sr.No. 22 Of Terms and Condition)	Comply Yes/No (In case of No Please provide details)
8	Udhyog Aadhar No. & Category (Micro/Small Enterprise, Also specify firm is owned by SC/ST/Woman/General)	
9	HSN/SAC Code	
10	Discount(if any)	
11	Remarks	

* Fill in the applicable details

Place:

Authorised Signatory:

Date:

Company Seal

Wall mounted maintenance platform with ladder- fabrication and installation work

1. Scope of Supply

Fabrication & installation of wall mount maintenance platform with ladder as per drawing.

2. Scope of Work

The supplier shall be responsible for the following main scope of work:

1. Procurement of all required materials/items as per the specifications and as per the attached schematics & drawings in Annexure-1.
2. Appropriate safe packing of the material and delivery to ITER-India site
3. Cutting, machining and fabrication of suitable components with appropriate dimensions like C Channels, L angles, strips etc. as per attached schematics & drawings in Annexure-1.
4. It is mandatory to remove/ blunt sharp edges and corners for safety point of view.
5. One coat of primer and two coats of good quality and ITER-India approved paint need to be used for all components.
6. Installation of platform and ladder is in bidder's scope, so bidder has to arrange/manage all material handling equipment (MHE) like scaffolding, ladders etc. required for the task.
7. Final installation work is to be completed at 3rd floor of ITER-India Lab building **at height of approximately 4.5 meters from 3rd floor**, so planning related to material handling and movement is to be finalized well before dispatching the material at site.
8. It is within the contractor's scope to propose any necessary changes and improvements in the design to meet the fabrication/ assembly/ installation requirements.
9. Supplier to present/submit material test certificates for any of the procured raw materials if requested by ITER-India.

3. Drawings & Detailed Specifications

- 3.1 Detailed drawings: Detailed drawings in annexure-1 consisting of all necessary specifications are attached here with.

	Annexure-A Technical Specifications	Enquiry No.:
		I-IEN22029

3.2 Key Specifications and BOM for fabrication of work:

S. No.	Component Description	Material Specifications (dimensions are in mm)	Quantity	Bidder Specification/ Compliance
1.	Chequered plate	1000 x 1200 x 5	As per annex-I	
2.	C channel	75 x 40 x 4	As per annex-I	
3.	L angle	50 x 50 x 5	As per annex-I	
		30 x 30 x 3	As per annex-I	
4.	Wall Plate	150 x 150 x 8	As per annex-I	
5.	Fencing support/ strip	1000 x 30 x 3	As per annex-I	
6.	Box Pipe	32 x 32 x 3	As per annex-I	
7.	Anchor Fastener	Ø12x150	45 Nos	

Table 1: Specifications for fabrication

4. Prefabrication & Quality Control

- Random inspection may be organized by ITER-India for inspecting the quality of procured material/components and observation of fabrication processes for platform & Pipe ladder welding work (in case fabrication is done at bidder's workplace).

5. Safety practices during site activity

- ✓ All relevant safety equipment need to be assured by contractor for working at height for job install.
- ✓ All necessary safety precautions shall be taken by contractor while executing the work, for ensuring a hazard free environment, including minimizing risks to workers, ITER-India staff members and visitors.
- ✓ The Contractor is accountable for safety and insurance of his personnel working at site as well as all its equipment/ material & shall ensure all the time.

6. Safety requirements:

- ✓ The Supplier shall take all necessary precautions to ensure safety of personnel deployed for the said work. As the work is to be executed in a restricted area, the Supplier shall strictly observe all safety, security and labour regulations prevailing in the campus. The Supplier shall be responsible and accountable for the proper behavior of the staff employed by him and also for any breach of security regulations, thefts, sabotage etc. The Supplier shall withdraw

7. Accident/Third Party Liability:

- ✓ The Service Provider will take all possible precautions to avoid damage to the Purchaser's property during its onsite activities. Service Provider shall also take insurance covering third party liability for the personnel and Equipment's and/or tools deployed at Purchaser's site against all risks, such as injuries, loss of life etc. Service Provider will be fully responsible for payment of compensation. In the event of loss and/or damage to Purchaser's property / any item(s) / equipment and/or injury or loss of life to Purchaser's personnel during the course of onsite activities due to the Service Provider's default. Service Provider will be fully responsible and liable for such damages and/or losses and payment of appropriate compensation as assessed by the Purchaser. Service Provider will relieve the Purchaser from all the risk and liabilities under this clause.

8. Termination for Default

- a) The Purchaser may, without prejudice to any other remedy for breach of Contract, by written notice of default sent to the Contractor, terminate the Contract in whole or in part in circumstance detailed hereunder:
 - i. If the Contractor fails to provide ordered service, within the time period(s) specified in the Contract or any extension thereof granted by the Purchaser.
 - ii. If the Contractor fails to perform any other obligation(s) under the Contract within the period specified in the Contract or any extension thereof granted by the Purchaser

- b) In the event the Purchaser terminates the Contract in whole or in part, the Purchaser may take recourse to the following actions. However, the Contractor shall continue to perform the Contract to the extent not terminated
 - i. To cancel the total Contract or balance portion thereof, and if so desired, to purchase or authorize the purchase of the ordered service not so delivered or other deliverable(s) of similar description, when such deliverable(s) exactly complying with the particulars are not, in the opinion of the Purchaser, readily procurable, such opinion being final, at the risk and cost of the Contractor.

- c) If the order is terminated as provided in this clause, the Purchaser in addition to any other rights provided in the clause, may require the Contractor to transfer title and deliver to the Purchaser any completed items that are found to be useful and acceptable to the Purchaser. The Purchaser shall

	Annexure-A Technical Specifications	Enquiry No.:
		I-IEN22029

pay to the Contractor, the Contract price of such completed items that are delivered to and accepted by the Purchaser

9. Care of Property & Hygiene

- ✓ Any equipment/ material issue by ITER-India shall be stored & return properly. Any damage to free issue material shall be recovered from contractor.
- ✓ **The Contractor is responsible for cleaning up the work area after completion of the work to the satisfaction of the ITER-India technical representative.**

10. Completion Period

The delivery period shall be 4 weeks from the date of PO placement.

11. Packing and Shipment

Packing: Appropriate packaging must be done to avoid damage during transportation. Transportation and Unloading are under the scope of supplier. Items shall be delivered at:

ECH-Lab, Third floor,
ITER-India Lab Building,
Institute for Plasma Research,
Near Indira Bridge, P.O. Bhat
Gandhinagar -382 428, India

Prior information of the material dispatch shall be given to ITER-India Purchase Officer

12. Final Acceptance

- ✓ The properly fabricated and installed structure of wall mount platform with ladder will be inspected by ITER-India for proper workmanship. If found satisfactory, the final acceptance will be given.

13. Warranty

The Supplier should provide one-year standard warranty, i.e., repair/replace free of cost in case of a failure or material defects during the warranty period.



Annexure-A Technical Specifications

Enquiry No.:

I-IEN22029

14. Bid Submission

- ✓ Bidder has to study all the drawings thoroughly and in case of any query/question, it should be sought from ITER-India before bid submission.
- ✓ As a confirmation that bidder has gone through the drawings and understood the full scope of work, signed & stamped copies of all the drawings are to be submitted along with the bid.

15. Annexure-I: List of drawings & schematics

S. No.	Description	Sheet No
1	Platform assembly isometric view	01
2	Platform part details including Bill of Materials	02
3	Ladder assembly details including Bill of Materials	03
4	C section assembly details	04

Table 2: List of drawings for the project

Bidders Signature		
Name of the Signatory & Title	Name	Title
Bidder's Official seal		
Place & Date	Place	DD-MM-YYYY



Annexure-A Technical Specifications

Enquiry No.:

I-IEN22029

Annexure-1: List of drawings & schematics

	Annexure-A Technical Specifications	Enquiry No.:
		I-IEN22029

Annexure-II:

Self-declaration by Bidder of a country sharing/not sharing land border with India

[ON THE LETTER HEAD OF THE COMPANY]

Ref: 1) Our bid/offer No. dated

2) Enquiry for Wall mounted maintenance platform with ladder- fabrication and installation work

Restrictions on procurement from Bidders from a country or countries, or class of countries under Rule 144(xi) of the General Financial Rules 2017.

We have read the clause regarding restrictions on procurement from Bidder of a country which shares a land border with India and on sub-contracting to contractors from such countries, and solemnly certify that we fulfil all requirements in this regard and are eligible to be considered.

We certify that:

- (a) *we are not from such a country or, if from such a country, we are registered with the Competent Authority (copy enclosed). and;*
- (b) *we shall not subcontract any work to a contractor from such countries unless such contractor is registered with the Competent Authority and solemnly certify that we are not from such a country or, if from such country, we are registered with the Competent Authority (copy enclosed). We hereby certify that we fulfil all requirements in this regard and are eligible to be considered."*

Penalties for false or misleading declarations:

We hereby confirm that the particulars given above are factually correct and nothing is concealed and also undertake to advise any further changes to the above details. We understood that any wrong or misleading self-declaration by us would be violation of Code of integrity and would attract penalties as mentioned in this tender document, including debarment.

Signature
stamp
Name:
Position:
Address:
Tel:
Fax:

Bidder's

	Annexure-A Technical Specifications	Enquiry No.:
		I-IEN22029

Annexure – III

(to be printed in letter head)

Self-Certification under preference to Make in India order

Certificate

In line with Government Public Procurement Order No. P-45021/2/2017-PP (BE-II) dated 04.06.2020 as amended from time to time and as applicable on the date of submission of tender/enquiry, we hereby certify that we M/s _____ are Class I local supplier/ Class II local supplier/Non-Local supplier and quoted item/service against ITER-India Enquiry/Tender No.
Dated has/have local content i.e., ____%. Details of location at which local value addition will be made as follows:

We also understand, false declarations will be in breach of the code of integrity under rule 175(1)(i)(h) of the General Financial Rules for which a bidder or its successors can be debarred for up to two years as per Rule 151(iii) of the General Financial Rules along with such other actions as may be permissible under law.

Thanking You

Signature with date:

Name:

Designation:

Official Seal

- Notes:- 1. Details of "L angle supports" are separately added in BOM.
 2. All dimensions are in mm.
 3. All sharp corners must be smooth.
 4. Dimension are suit to site.

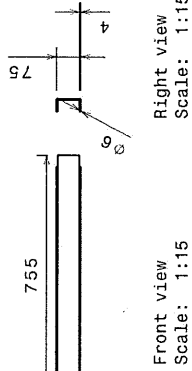

Details of part no. 6

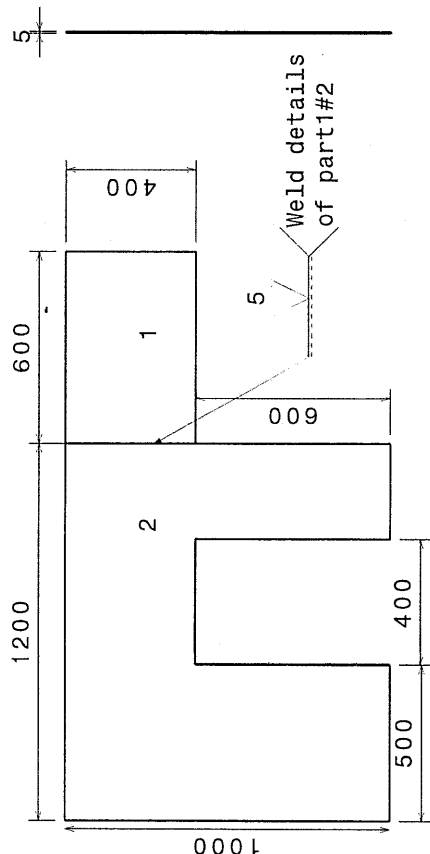

Right view
Scale: 1:15

Details of part no. 1 & 2

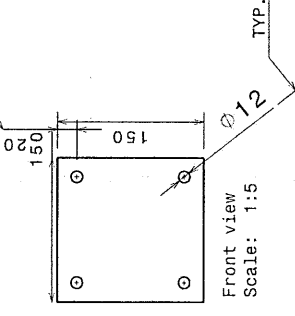

Details of part no. 18

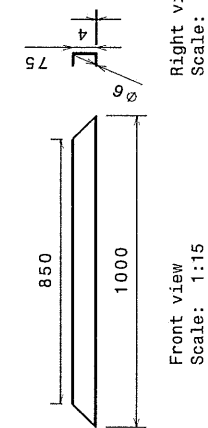

Details of part no. 3 & 5

Front view
Scale: 1:15

Right view
Scale: 1:15

Details of part no. 4

BOM				
Part no.	Description	Dimensions	Quantity	Mat.
1	Chequered plate-1	As per dwg.	1	M.S.
2	Chequered plate-2	As per dwg.	1	M.S.
3	C channel support 1	As per dwg.	2	M.S.
4	C channel support 2	As per dwg.	2	M.S.
5	C channel support 3	As per dwg.	1	M.S.
6	C channel support 4	As per dwg.	1	M.S.
7	L angle support 1	30X30X3X660	1	M.S.
8	L angle support 2	30X30X3X215	2	M.S.
9	L angle support 3	30X30X3X1000	1	M.S.
10	L angle support 4	30X30X3X280	1	M.S.
11	L angle support 5	30X30X3X630	1	M.S.
12	L angle support 6	30X30X3X340	1	M.S.
13	L angle support 7	30X30X3X880	1	M.S.
14	L angle support 8	30X30X3X400	1	M.S.
15	L angle support 9	30X30X3X570	1	M.S.
16	L angle support 10	30X30X3X140	1	M.S.
17	L angle support 11	30X30X3X200	1	M.S.
18	Wall plate	As per dwg.	6	M.S.
19	Fencing support 1	500X30X3	13	M.S.
20	Fencing support 2	1640X30X3	2	M.S.
21	Fencing support 3	950X30X3	2	M.S.

SITE LOCATION-ECRH LAB
 CONFIDENTIAL UNLESS AUTHORISED
 The information on this drawing is confidential under the terms of the ITER agreement. This information shall not be transmitted to anyone who is not authorised to receive it.
 DRAWING TITLE

REV. DATE	DD	MM	YY
THIRD ANGLE PROJECTION	SCALE		
SHEET SIZE	A3		
TOP SHEET	01		
RELEASED BY	-----		
APPROVED BY	-----		
CHECKED BY	-----		
CONTROLLED BY	-----		
DRAWN BY	-----		

PLATFORM PART DETAILS

DRAWING NUMBER	DISCNC-01
SHEET	02
REVISION	01
STATUS	

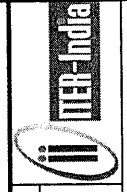

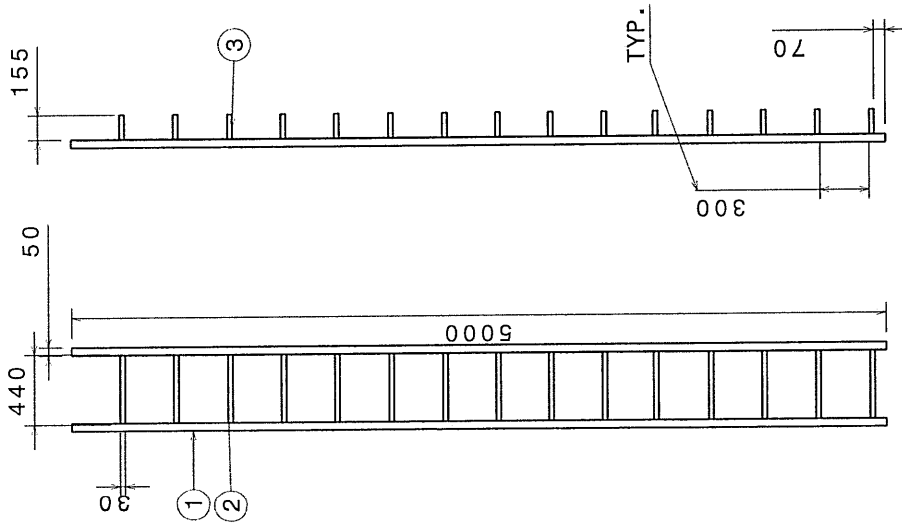

Front view
Scale: 1:30

Right view
Scale: 1:30



Bottom view
Scale: 1:30

BOM				
Part no.	Description	Size	Qty.	Mat.
1.	L angle support	50X50X5X5000	2	M.S.
2.	Box channel 1	30X30X3X440	15	M.S.
3.	Box channel 2	30X30X3X155	30	M.S.

Isometric view
Scale: 1:25

		SITE LOCATION-ECRH LAB CONFIDENTIAL UNLESS AUTHORISED The information on this drawing is confidential under the terms of the ITER agreement. This information shall not be transmitted to anyone who is not authorised to receive it.	
REV. DATE DD MTH YR A3	SCALE 1:30	RELEASED BY ----- APPROVED BY ----- CHECKED BY ----- CONTROLLED BY ----- DRAWN BY -----	DRAWING TITLE MS Ladder Assy.
THIRD ANGLE PROJECTION		NO. OF SHEETS 01	DRAWING NUMBER MSLDR_01
		SHEET 03	REVISION 01
		STATUS 01	8

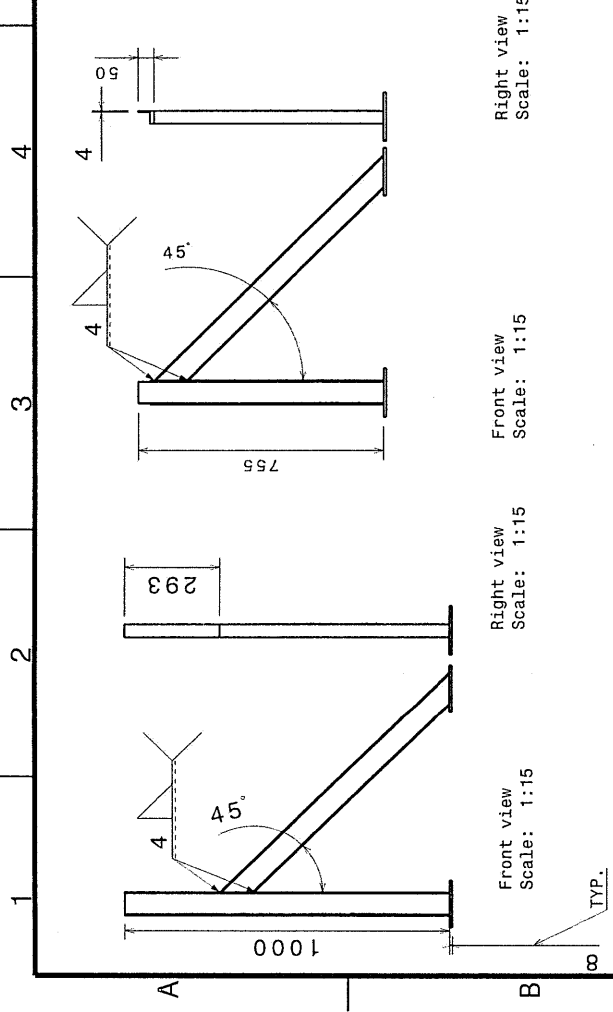
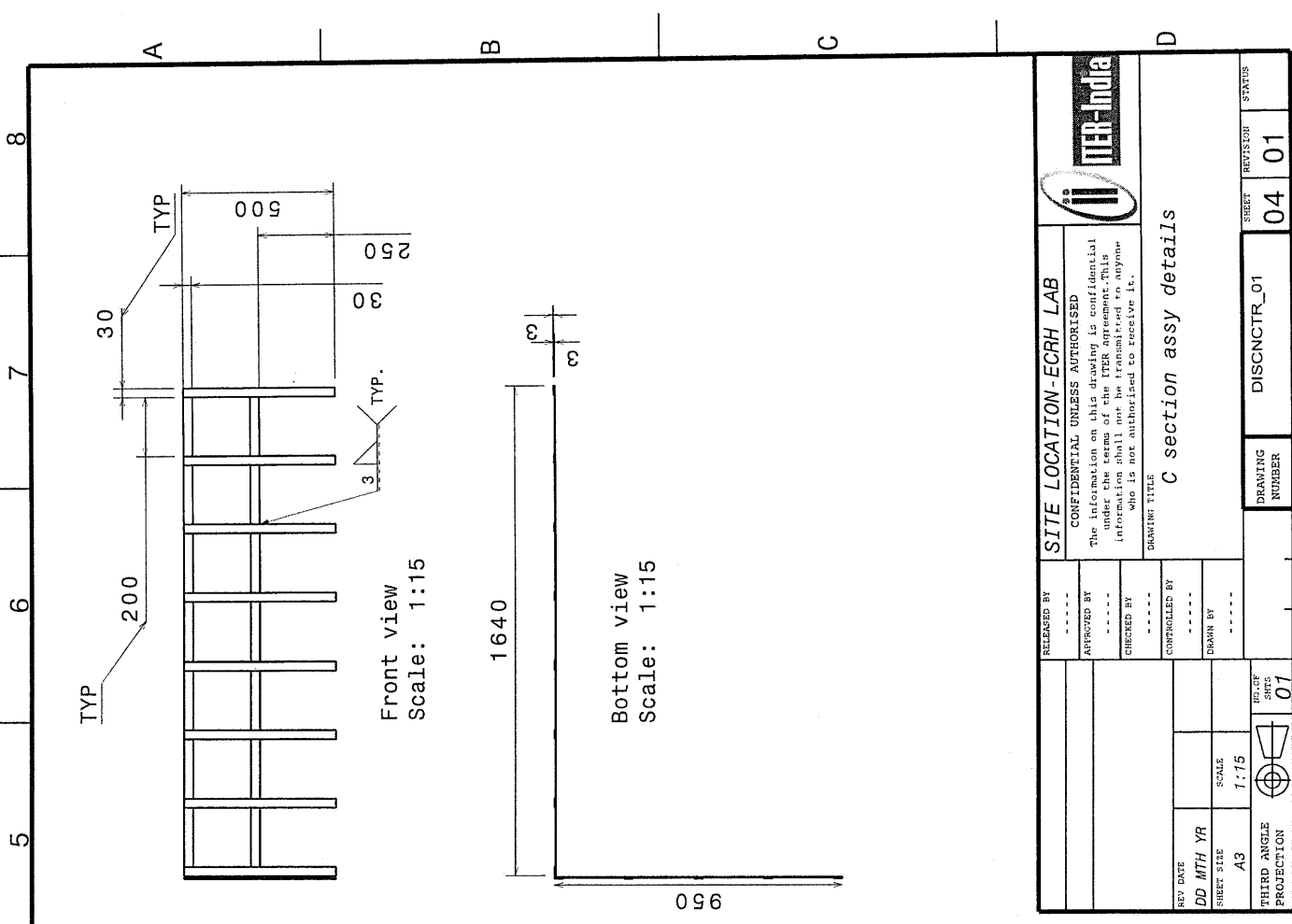

Details of assembly 1 and 2

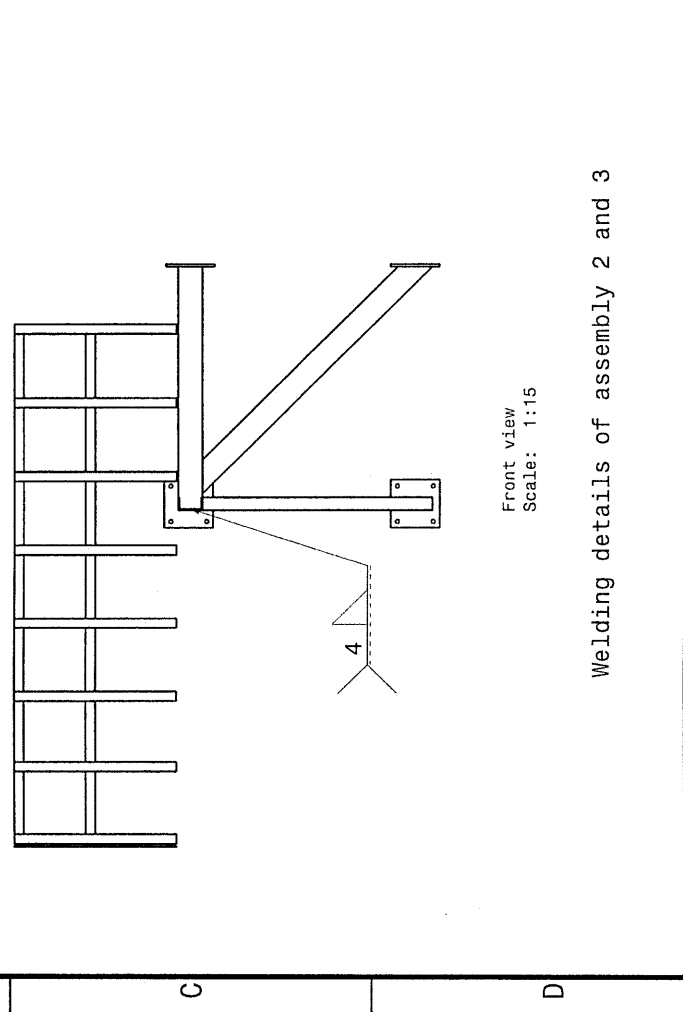

Details of assembly 3



		SITE LOCATION-ECRH LAB CONFIDENTIAL UNLESS AUTHORIZED The information on this drawing is confidential and its use without the express agreement of this organization shall not be transmitted to anyone who is not authorized to receive it.	
REVISED BY	-----	APPROVED BY	-----
CHECKED BY	-----	CONTROLLED BY	-----
DRAWN BY	-----	DRAWN BY	-----
REV DATE		DD MTH YR	
SHEET SIZE	A3	SCALE	1:15
THIRD ANGLE PROJECTION		USP SHEETS	01
DRAWING NUMBER		DISCNCTR_01	
SHEET		04 01	
REVISOR		STATUS	
8		8	

C section assy details